

ECTA Safety Recommendations for Winding Heads for double belt Spiral Winding Machines

Preliminary remarks:

In the tube and core industry, the equipment in use differs in size, type and operation, depending on the manufacturer. The ECTA Safety Committee has made an effort to take into account all the existing differences in writing these safety recommendations. The committee advises you to take national standards and norms into account when applying ECTA safety recommendations. The current Machinery Directive 2006/42/EC and the relevant CE norms are to be observed as well.

Recommended safety features on double head winders:

- I. Protective casing for the "winding heads": Protects access to the operator-side drive heads.
- II. Quick stop pedal: Immediate stop by foot action.
- III. Front safety cable: Immediate stop if triggered. Push or pull.
- IV. Safety scanner: Immaterial protection of the front (operator side) and the end of the machine. An audible alarm is activated when the operator approaches the stop zone.
- V. Rear safety cable: Immediate stop if triggered. Push or pull.
- VI. Rear light curtains: Immaterial protection of the rear area of the machine. Immediate stop when crossed. Fences prevent passage between the machine and the light curtains.

An example of a safety concept for winding machines is enclosed as an appendix. The example refers to a machine for double belt spiral winding machines.

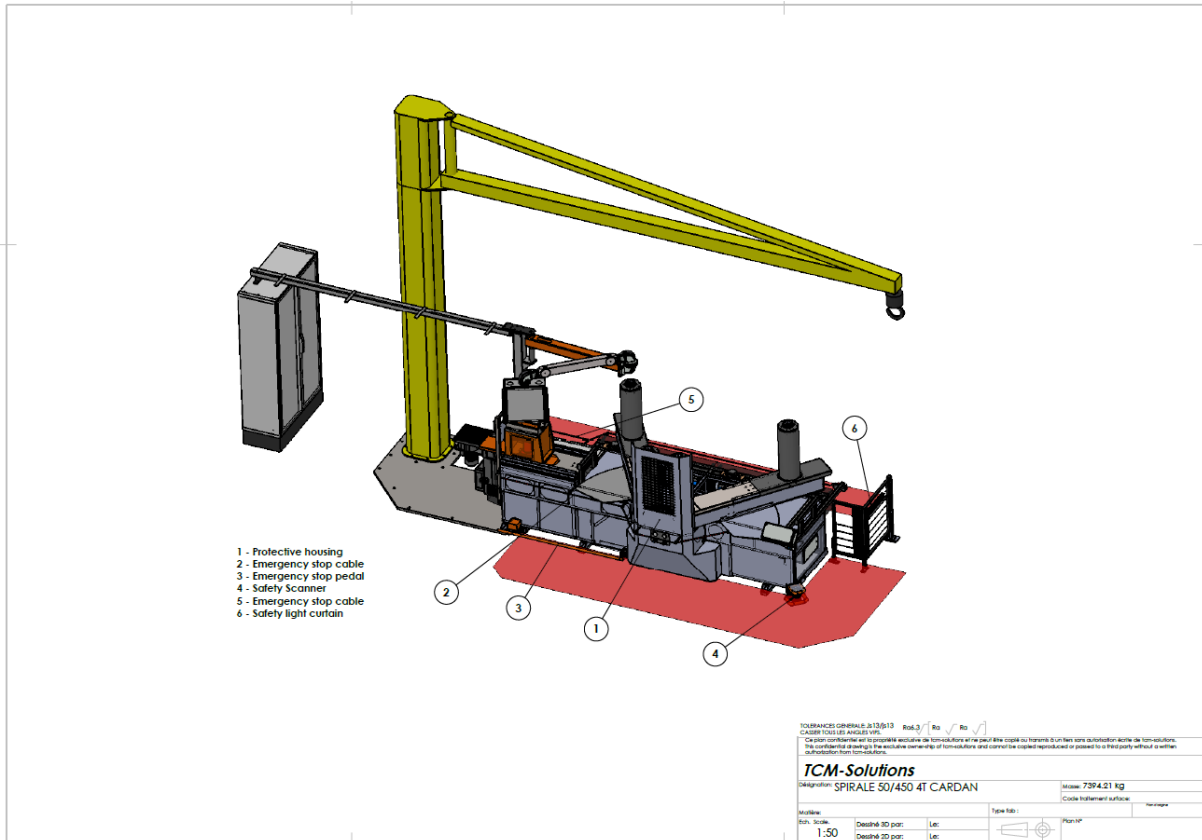

Remarks:

The CE symbol is no longer valid when significant changes to the machine occur. Approval of the safety concept by institutions responsible for inspections at the national level is highly recommended.

Waiver of liability:

ECTA has made an effort to draft these safety recommendations in good faith using the knowledge available to us. The recommendations are non-binding. Claims of guarantee cannot result from following them. The recommendations do not release members from informing themselves of the current legal regulations and of their individual application needs.